

HS-100A Technical Data Sheet

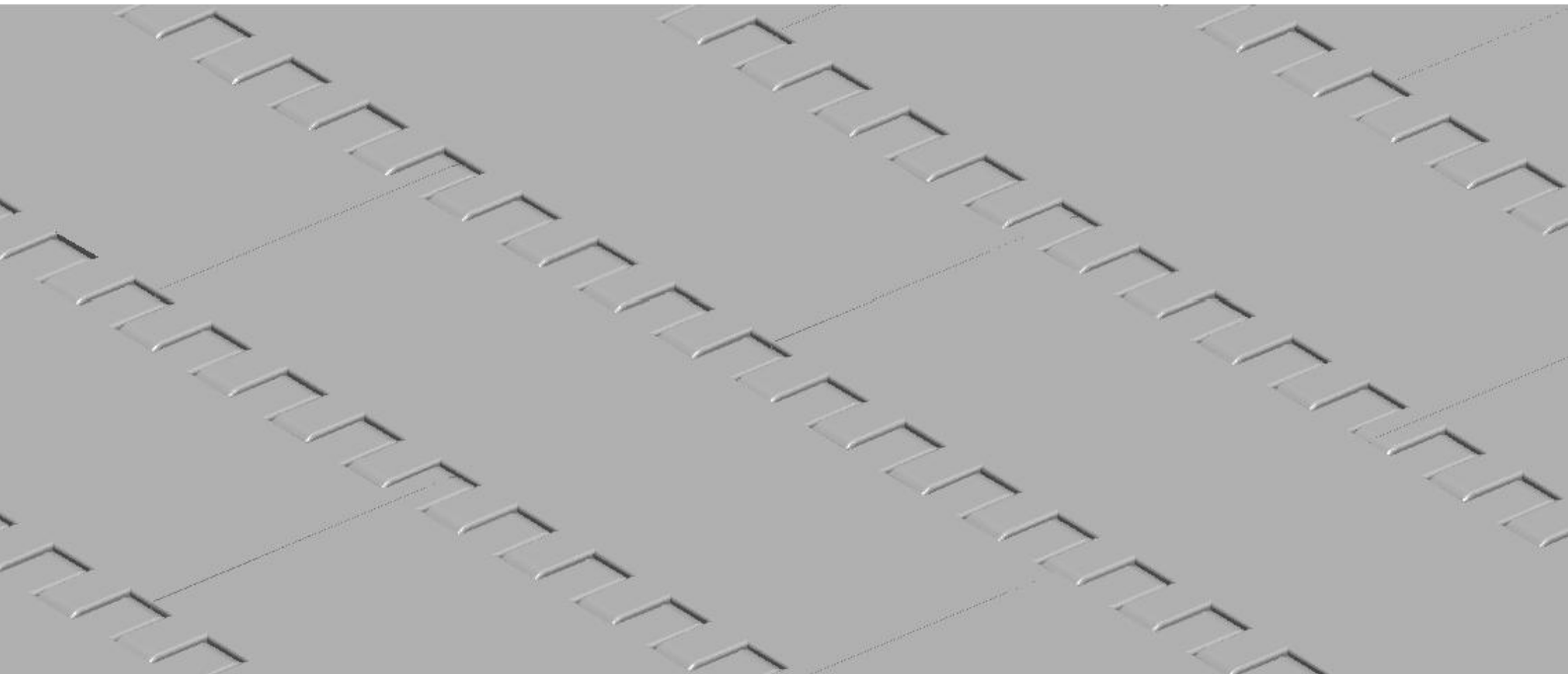

Pitch: 50.8mm Minimum Width: 150mm Open Area: 0% Approved: FDA Rod: Ø 5.8mm Flight: Yes Side Guard: Yes Curve: No	
--	--

Data

Belt Material	Belt Strength			Temperature		Belt Weight (Kg/M ²)
	Straight		Curve	°C (min.)	°C (max.)	
	Kg/M(BW)	N/M(BW)				
Polypropylene	1340	13400	--	1	100	9.0
Polyethylene	1280	12800	--	-60	60	9.2
Acetal	1770	17700	--	-40	80	12.8
Nylon	1520	15200	--	1	180	11.3

BW – Belt Width

Color Table

Polypropylene					Polyethylene					Acetal					Nylon				
W	G	N	DB	B	W	G	N	DB	B	W	G	N	DB	B	W	G	N	DB	B
●	●						●			●				●				●	

W-White, G-Gray, N-Nature, DB-Dark brown, B-Blue

Friction Table

Belt Material	Friction Wear strips & Products							
	UHMW	HDPE	Steel	Glass	SUS	Plastic	Cardboard	Aluminum
Polypropylene	0.32	0.24	0.15	0.09	0.13	0.08	0.15	0.25
Polyethylene	0.13	0.11	0.26	0.19	0.31	0.16	0.21	0.41
Acetal	0.11	0.09	0.27	0.16	0.26	0.15	0.19	0.28
Nylon	0.18	0.13	0.25	0.16	0.26	0.16	0.19	0.27

SUS – Stainless Steel

Equivalent type with other Brand

Brand Name	Intralox	UNI	Rexnord	MCC	Habasit	KVP
Series & Type	200	OPB	6390	2000	H5000	620
	800	L-SNB	2010		M5100	
	850	MPB	2000			

The above content is only for reference.

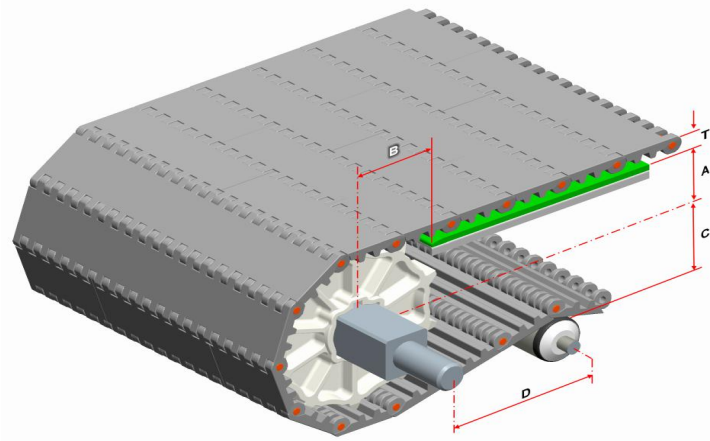

Conveyor Frame Dimensions					Unit : mm
No. Teeth	A (Min.)	B (Min.)	C (Max.)	D (Min.)	T
6	37.9	55.9	33.9	250	16
8	56	74	52	250	
9	63.5	81.5	59.5	250	
10	73	91	69	250	
12	88.4	106.4	84.4	300	
16	122	140	118	300	

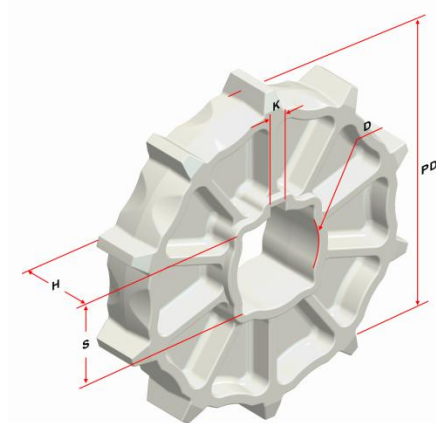

Sprocket Dimensions					Unit: mm
No. Teeth	PD	S	D	H	K
6	91.8	38.5/40.5	25.5/30.5/35.5/45.5	30	8X8
8	128	38.5/40.5	25.5/30.5/35.5/40.5/44.5	37	7X7
9	143	38.5/40.5	32.5/45.5/51	35	8X8
10	162	38.5/40.5/50.5/60.5	25.5/30.5/35.5/40.5/45.5	35	8X8
12	192.8	38.5/40.5/60.5	45.5/47.5	37	8X8
16	260	38.5/60.5/63.5	--	46	--